

1200L PACKAGED PUMP STATION

GREY WATER

IDEAL FOR DOMESTIC DRAINAGE AND GREY WATER APPLICATIONS

PACKAGE INCLUDES

- Heavy Duty Roto-molded 1200 L polyethylene tank
- REEFE RVS200 submersible pump with automatic control
- Complete with 40mm discharge piping, valves and fittings including brass gate and swing check valve, and barrel union for easy connection and pump removal
- High level alarm with audible and visible alarm functions
- Australian made and assembled ready for installation



REEFE Liquid Level Alarm
(RLA10)



REEFE Submersible Pump
(RVS200)



Cast Iron Impeller
Components

FEATURES

- 1200L Nominal Capacity
- Approved to requirements of Australian Standard AS/NZS1546.1
- Tough UV stabilised rotationally moulded polyethylene vessel
- Proven UV stabilised injection moulded lid (RELN Septic Tank)
- Easy 100mm PVC Sewer Pipe inlet connection via Pipe Seal Gasket
- Variable inlet height to suit fall or volume required (between 1000L and 900L). Simply drill to desired height in marked positions
- Flanged base designed for hold-down by backfill
- Unique tie down locations on underside of base suit attachment with reo bar set and additional unique flange penetrations for concrete lock down in higher water table areas
- Specially shaped base designed for
 - maximum strength
 - maximum pump out
- Class B & Class D Ductile Iron Access Cover options
- Dual Pump Systems available

1200L PACKAGED PUMP STATION REEFE RVS200 DETAILS

GREY WATER

ELECTRICAL DATA

- Rated Voltage: 240V
- Mains Frequency: 50Hz
- Rated output: 450W
- Current: 3.0A
- Capacitor: 15 μ F
- Motor Duty: Continuous
- Motor Type: Asynchronous
- Motor protection: Built-in thermal overload
- Ingress protection: IP68
- Insulation class: F
- Power cable length: 10m H07RNF

LIQUIDS

- Clean water temperature range: 2 - 35 °C

MATERIALS

- Pump body: Cast Iron
- Impeller: Cast Iron
- Motor Shaft: Stainless Steel
- Shaft seal: Dual mechanical seals (Ceramic/Carbon)

INSTALLATION

- Max. Ambient temperature: 40°C
- Pipe Connection: 2"

SPECIFICATIONS

Overall height: 1698mm
Overall diameter: 1250mm
Weight: 100kg
Nominal Capacity: 1200L

HYDRAULIC PERFORMANCE CHART

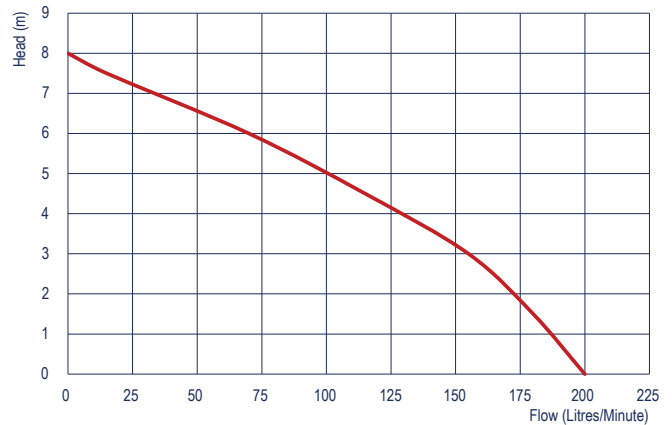

SITE EXCAVATION DIMENSIONS

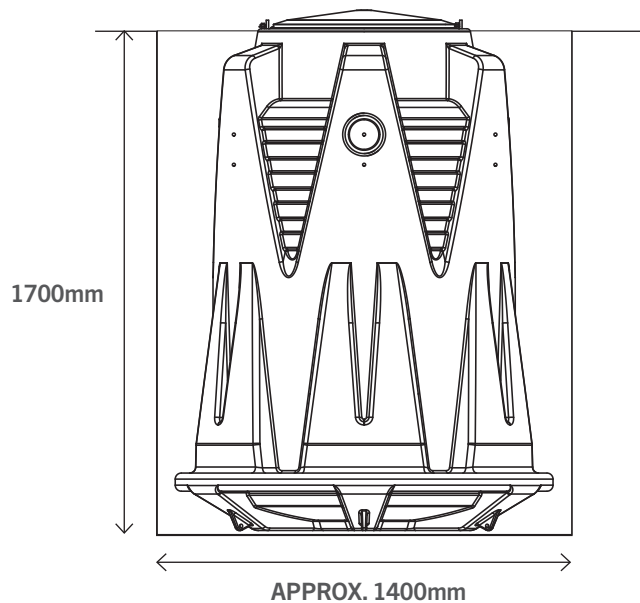

CONTACT US

Alphatreat Pty Ltd
ABN 64 143 207 658

9 Mackie Way, Brendale, QLD, 4500
Phone: 07 3205 3666
Facsimile: 07 3205 7155
Hours: 7:30am - 4:00pm (Mon-Fri)
Email: info@wastewaterequipment.com.au

wastewaterequipment.com.au